

The Variable DC Approach in Fuel cell And Battery Powered Marine Power Systems: Control of The Fuel Cell Power Converter

Arber Haxhiu^{1,*}, Jorma Kyyrä², Ricky Chan³, Sami Kanerva¹

¹ Electric Solutions, ABB Marine and Ports, Finland,
Email: arber.haxhiu@fi.abb.com, sami.kanerva@fi.abb.com

²Department of Electrical Engineering and Automation, Aalto University, Finland,
Email: jorma.kyyra@aalto.fi

³ Automation and Control, ABB Marine and Ports, Finland,
Email: ricky.chan@fi.abb.com

* Corresponding author

Abstract: Previously, the Variable DC approach concept was proposed for operation of hybrid fuel cell and battery powered marine vessels. The concept was shown to provide significant efficiency improvement, and consequently improved hydrogen fuel savings. However, although the general concept and the control of battery DC/DC converter has been detailedly described in previous works, the operation of fuel cell DC/DC converter in different Variable DC approach control modes has not been presented. This paper proposes a fuel cell DC/DC converter control system specifically designed for operation in the three Variable DC approach control modes. The functionality of the proposed fuel cell DC/DC converter and the Variable DC approach in general is verified using a hardware-in-loop test setup consisting of virtual power stage models and real converter controllers. The system is shown to function well in both normal operating conditions and various fault conditions.

Keywords: Converter control, Drivetrain, Efficiency, Fuel Cells, Hybrid, Marine, Power System, Variable DC Voltage.

I. INTRODUCTION

The maritime industry is going through a significant transition from harmful emissions generating carbon-based power sources towards greener, less air polluting, power sources. This transition is primarily being driven by the ever-tightening regulation on emissions created by onboard power generation. Some of the more known recent regulation changes are those from the International Maritime Organization (IMO) requiring the greenhouse gas emissions to be halved by 2050 from the levels of 2008 and for the sulfur content from ship fuel to be capped at 0.5% since 2020. In order to comply with the ever-tightening regulation, ship operators are looking for alternative sustainable solutions for onboard power generation. Towards that end, hydrogen fuel cells and electric batteries have been emerging as the potential and promising means for zero-emission shipping. However, especially for hydrogen and fuel cells, their broader adoption in the Maritime industry is still being hindered by high cost and limited availability of green hydrogen. To accelerate the adoption of hydrogen fuel cells as the main power sources in marine vessels, much research is being conducted towards efficient and cost-effective electric power integration on board the vessels.

Fuel cells and batteries are both DC power sources with variable output voltage as a function of load current. They are typically integrated into vessel power distribution system via DC/DC converters which adjust the varying fuel cell voltage to a value required for DC power distribution. The power generated by the fuel cells and batteries is distributed to electric propulsion motors and other vessel load consumers via voltage source inverters (VSIs). A generic marine power system powered by fuel cells and batteries is shown in Figure 1. In such marine systems, the DC distribution voltage level is typically designed to enable the VSIs to operate at maximum power and the voltage is constantly controlled at the designed level.

However, many marine vessels typically operate at much lower loads than dimensioning or design set points and therefore, could benefit from variable DC bus voltages, which has been shown to reduce losses in semiconductor devices and electric machines [1] - [3]. For example, dynamic positioning vessels, offshore vessels and inland navigation vessels are known to spend up to 90% of total operating hours operating at partial loads, less than 60-70% of full power [4], [5].

In electric land-going vehicles, active control of DC supply voltage as function of electric motor speed is a commonly adopted technique [6] - [9]. The electric motors are typically operated via VSIs which transform a DC supply voltage into variable frequency AC voltage at the electric motor input terminals. Since, the required electric motor input voltage is proportionally dependent on the rotational speed of the motor, the DC supply voltage can be lowered from its nominal value when the electric motor is operating at speeds lower than nominal speed. The reduction in DC voltage has significant positive impact in the efficiencies of both the VSI and the motor [10]. When the DC supply voltage is varied according to the electric motor operation point, the current ripples, and consequently flux density ripples in the electric motor are reduced, and thus the efficiency of both VSI and electric motor is improved. The improvement in efficiency is especially significant at the lower operating speeds. However, such control technique is not viably transferred into electric marine vessels where the same DC supply (or DC bus) voltage is typically used to feed both propulsion motors and all the rest

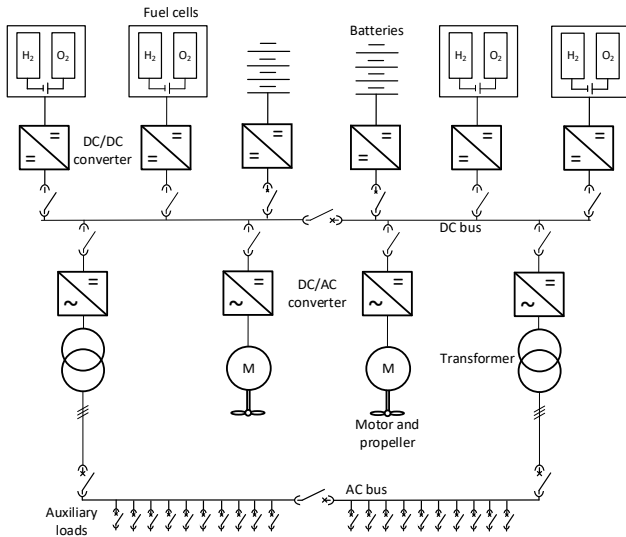

Fig. 1. A generic marine power system powered by fuel cells and batteries. The auxiliary loads comprise all onboard loads other than propulsion (e.g., lighting, navigation equipment and heating and air conditioning)

of onboard load consumers (e.g., lighting, navigation devices, heating and air conditioning), as shown in Figure 1. Even when the propulsion motors are operating at very low speeds and could sustain low DC bus voltage, the rest of loads would still require full DC bus voltage. Therefore, such control strategies are rarely considered in marine vessels.

Instead, a novel system control technique utilizing variable DC supply voltage and targeting specifically marine applications powered by fuel cells and batteries has been proposed in [11] - [13]. Like the techniques proposed for electric vehicles, this control technique is also based on variable DC bus voltage and aims at optimization of powertrain efficiency. However, the criteria for controlling the DC bus voltage are completely different from the techniques used in the electric vehicles. In the technique proposed in [11] - [13], the DC bus voltage is varied according to the fuel cell operating point instead of the electric motor operating point. Moreover, the DC bus voltage is only slightly varied (about $\pm 5\text{-}10\%$) around the nominal level, and thus always allows for full voltage for all the onboard power loads. This control technique is called the Variable DC approach and is shown to reduce fuel cell converter losses through the voltage variation [12].

This paper continues the research started [11] - [13] by proposing a new control system for a fuel cell DC/DC converter operating in the Variable DC approach. From the control perspective, the previous works on the Variable DC approach have been mainly focusing the general system philosophy and control of battery DC/DC converter. Therefore, internal control of fuel cell DC/DC converter and its requirements have not yet been covered. Instead, those aspects will be presented and discussed in this paper.

This paper is organized as follows. Section II presents the general operating philosophy of the Variable DC approach. The proposed fuel cell DC/DC converter control system is set forth in Section III. The test setup used for validation of the proposed control system is described in Section IV. The results of the proposed approach are presented in Section V. The paper concludes with discussion and recommendations of future research in Section VI.

II. CONTROL OF THE FUEL CELL DC/DC CONVERTER

The general concept of the Variable DC approach for hybrid fuel cell and battery marine power systems has been previously presented in [11] and [12]. It was designed to minimize power train losses of a fuel cells and batteries fed marine power system by operating fuel cell DC/DC converters in Freewheel mode where the fuel cell converter switches are kept static instead of switching according to pulse width modulation (PWM) commands. Consequently, the efficiency of the fuel cell DC/DC converters is significantly improved due to elimination of switching losses in converter semiconductors and passive devices i.e., capacitors and inductors.

In the Variable DC approach, the fuel cell DC/DC converters are proposed to be operated in one of three operating modes (Buck, Freewheel or Boost) depending on the fuel cell output voltage. The fuel cell voltage varies significantly according to its output current as illustrated in Figure 2. However, as mentioned earlier, the operating range for the DC bus voltage is typically limited within a certain range, $[V_{dc_min}, V_{dc_max}]$, e.g., within 650 - 780V in the illustration of Figure 2. At low fuel cell loads, the fuel cell voltage is typically higher than allowed at the DC bus, and thus the Buck mode must be used to step down the fuel cell voltage. On the other hand, at high fuel cell loads, the fuel cell voltage is typically lower than allowed at the DC bus, and thus the Boost mode must be used to step up the fuel cell voltage. However, at medium loads, the fuel cell voltage tends to be within the DC bus voltage operating range, and hence fuel cell power conversion is not needed. This mode is called the Freewheel mode because the fuel cell current is allowed to freely flow towards the DC bus without any PWM control on the fuel cell DC/DC converter. However, although the fuel cell DC/DC converter is left uncontrolled in the Freewheel mode, the fuel cell power is still controlled in the system. The power control is managed through control of DC bus voltage via the battery DC/DC converter. Increasing the DC bus voltage leads to decreasing the fuel cell power, whereas decreasing the DC bus voltage leads to increasing the fuel cell power. The battery DC/DC converter control in the Freewheel mode is thoroughly described in [12]. Since the fuel cell DC/DC converter is not PWM controlled in Freewheel mode, the switching losses in the power converter are eliminated and the total system efficiency is significantly improved.

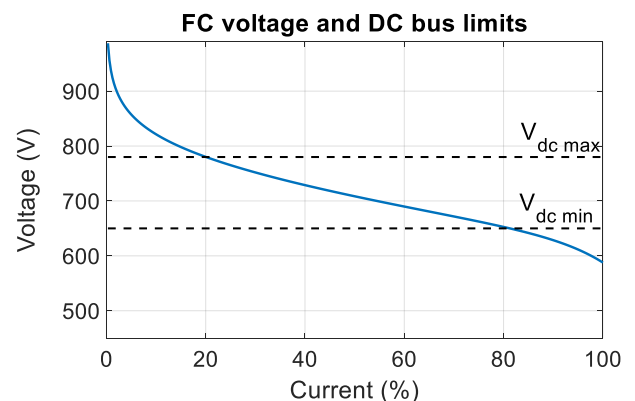

Fig. 2. Fuel cell voltage as function of current in percentage of fuel cell nominal current. The V_{dc_min} and V_{dc_max} are the minimum and maximum DC bus voltages, respectively.

III. CONTROL OF THE FUEL CELL DC/DC CONVERTER

The fuel cell DC/DC converter used in this work is illustrated in Figure 3. The converter utilizes a buck converter and a boost converter connected back-to-back. The Boost mode is typically used when fuel cell is highly loaded and therefore, three interleaved phases are used. On the other hand, Buck mode is used at low fuel cell loads (typically < 30%), and thus a single phase is sufficient. The converter must be capable of smoothly transitioning between Buck, Boost and Freewheel modes, while also protecting the fuel cell from potential failure events.

A control diagram of the control system proposed in this paper is illustrated in Figure 4. The control system utilizes two PWM modulators, one for buck converter and another for the boost converter. The modulators are designed such that a modulation index within [-1, 0] results into a PWM of buck converter and maintain boost converter switches off. A modulation index within [0, 1] results into a PWM of the boost converter and maintain the Buck converter switch on. Therefore, a modulation index of zero results in the converter operating in the Freewheel mode. The modulation index is generated by a controller which in Figure 4 is divided into six parts based on their control purpose:

- Mode selection
- Reference controller
- Current controller
- Anti-windup
- Current ramp rate controller
- Over- and undervoltage controller

The first part of the controller is the mode selector. The mode selector must determine which of the Variable DC approach control mode is to be used. In general, it functions as follows. If DC bus voltage is at its maximum value, V_{dc_max} , and the total system load is low enough for the fuel cell voltage to be above V_{dc_max} , the Buck mode is selected. If the load is high enough for the fuel cell voltage to be lower than V_{dc_min} , Boost mode is selected. When total load is such that fuel cell voltage is within $[V_{dc_min}, V_{dc_max}]$, Freewheel mode is selected. The knowledge which mode is to be used is needed by the anti-windup and the reference controller of the proposed control system.

The reference controller determines the non-limited current reference that the fuel cell DC/DC should follow during normal operation, i.e., when neither current ramp rate controller nor over- and undervoltage controller are active. As described in [11], in Buck and Boost modes, the fuel cell DC/DC converter current reference should be controlled such that the battery current ends up to zero in steady state. This is managed by summing the actual converter current and the battery current and using a rate limiter to limit the rate of change of their sum. The rate limiter determines the converter current rate of change. On the other, in Freewheel mode, the fuel cell current is not intended to be controlled by the fuel cell DC/DC converter, and thus the converter actual current is used as reference. This selection in Freewheel mode plays an important role in the operation of the current ramp rate controller as will be described below.

The role of a current controller is to minimize error between a current reference and feedback from an actual current measurement. In this control system, the well-known PI-controller is selected. The K_p and K_i are the proportional and integrator gains of the PI-controller, respectively.

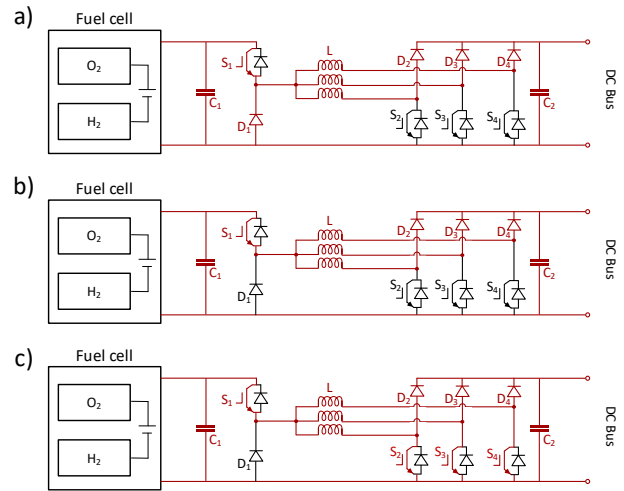

Fig 3. Operation of unidirectional buck-boost converter in a) Buck mode, b) Freewheel mode and c) Boost mode. The red color is used to highlight which components are in use in the respective modes.

The output of the PI-controller is fed into an anti-windup block which has two purposes. The first purpose, as an anti-windup for any PI-controller, is to prevent the integrator windup when limits are reached. However, the second purpose is to enable smooth transitioning between operation modes, and as such is specific for the proposed control system. The minimum and maximum values of the limiter in the anti-windup are dynamically changed during operation. If Buck mode is used, the minimum and maximum are -1 and 0, respectively, resulting in PWM control of only switch S_1 . In Boost mode the same are 0 and 1, respectively, resulting in PWM control of S_2 , S_3 and S_4 , while also maintaining the S_1 constantly on. In Freewheel mode, both minimum and maximum are 0, and thus S_1 is maintained on while S_2 , S_3 and S_4 are kept off. Without the described functionality in the anti-windup block, operation in Freewheel mode would not work as the controller would not be able to keep the modulation index zero due to constant variation in the current reference and the actual current. During normal operation, the minimum and maximum values for the anti-windup limiter are determined strictly by the active operation mode. However, in transient conditions where the converter current is not within the allowed operating range, the minimum and maximum values are overwritten by the current ramp rate controller.

As the name suggests, the purpose of the current ramp rate controller is to control the ramp rate of the fuel cell current. For any current controller generally, it is typical that the current ramp rate is controlled by limiting the rate of change of the current reference. However, when operating in the Freewheel mode, limitation of the current reference rate of change alone is not effective because fuel cell current is not controlled by the fuel cell DC/DC converter, but instead externally by the battery control system via DC bus voltage control as described in [12]. The current ramp rate method proposed in this paper is to have the current reference go through a limiter which has its minimum and maximum values dynamically varied depending on the actual converter current. The limiter creates a hysteresis band around the actual converter current, and when the upper or lower limits of the hysteresis band are exceeded, the current ramp rate controller activates and starts limiting the fuel cell current

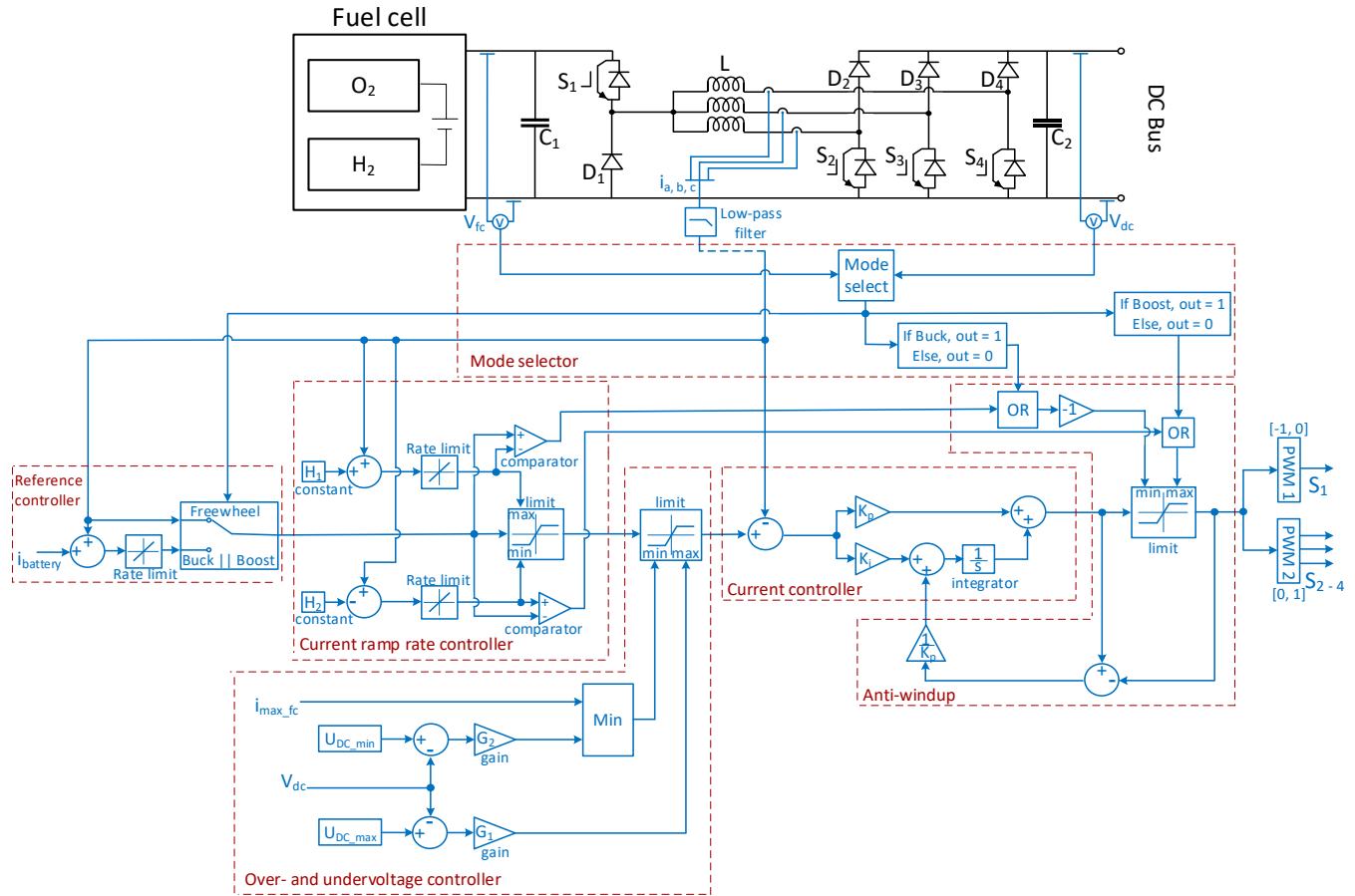

Fig. 4. A control diagram for fuel cell DC/DC converter operating in a system utilizing the Variable DC approach. The output of PWM 1 is used to control switch S_1 , whereas outputs of PWM2 are used for switches $S_2 - S_4$. In the figure, O_2 and H_2 refer to oxygen and hydrogen, respectively, $D_1 - D_4$ refer to diodes, C_1 and C_2 refer to capacitors and L refers to inductor.

rate of change. Notice, in Freewheel mode, the current reference (i.e., output of reference controller) is the same as actual current feedback. If the converter current operates within the hysteresis band, the current ramp rate controller is inactive and has no impact on the operation. The upper limit of the hysteresis band is determined by the sum of actual current and a constant H_1 , the sum which has its rate of change limited by a rate limiter. The rate limiter determines the ramp rate of the converter current. If the upper limit of the hysteresis band is exceeded, the minimum value of the limit in the Anti-windup is forced to -1. Simultaneously, the current reference is forced to the upper limit of the hysteresis band by the current ramp rate controller, and thus resulting in forced operation of the buck converter and limitation of the converter current. On the other hand, the lower limit of the hysteresis band is determined by the subtraction of actual current and constant H_2 , the subtraction which is also limited by a rate limiter. In case the actual current is below the output of the lower rate limiter, the maximum value of the limit in the anti-windup is set to 1. Simultaneously, current reference is forced to the lower limit of the hysteresis band by the current ramp rate controller, and

thus resulting in operation of the boost converter and limitation of the converter current.

The last part of proposed control system is the over- and undervoltage controller. The purpose of the over- and undervoltage controller is to rapidly decrease or increase the fuel cell current in case of a DC bus overvoltage or a DC bus undervoltage. This is managed by using a limiter with dynamic minimum and maximum values to limit the current reference going to the current controller. The maximum value of the limiter is determined by subtraction of maximum allowed DC bus voltage, U_{dc_max} , and actual DC bus voltage multiplied by a gain, G_1 . The gain determines how quickly the fuel cell DC/DC current is reduced as DC bus voltage approaches U_{dc_max} . Similarly, the minimum value of the limiter is determined by the subtraction of minimum allowed DC bus voltage, U_{dc_min} , and actual DC bus voltage multiplied by a gain, G_2 . However, the minimum value of the limiter is also limited by the maximum allowed fuel cell current, i_{max_fc} , which typically varies according to the fuel cell operating state. Exceeding the maximum fuel cell current must typically be prevented because it can lead to potentially damaging the cells from fuel starvation [14]. Therefore, the fuel current must be kept below the i_{max_fc} , even against the risk of DC bus

undervoltage. In order to protect the broader power system from undervoltage in such events, proper system adjustment, e.g., quick load reduction, is required.

IV. HARDWARE-IN-LOOP SETUP USED FOR THE CONTROL SYSTEM VALIDATION

In order to validate the functionality of the proposed fuel cell DC/DC converter control method in Variable DC approach, a real-time hardware-in-loop (HIL) test setup was built as illustrated in Figure 5. The test setup consists one half section of the generic power system illustrated Figure 1. In the setup, two fuel cells, a battery and a propulsion motor are virtually modeled using a Typhoon HIL604 simulator [15]. The battery DC/DC converter and the load VSIs are controlled using real converter control units. The battery and motor converters are controlled by HES880 control units [16] whereas the auxiliary load converter is controlled by an ACS880 control unit [17]. The PWM outputs and measurement feedback inputs between the real control units and the HIL simulator are connected as hardwired IO. The fuel cell DC/DC converter is controlled virtually by the control system proposed in Section III. The simulation step used for the power system simulation and the fuel cell converter control are $1\mu s$ and $50\mu s$, respectively.

V. HIL RESULTS AND DISCUSSION

The functionality of the proposed fuel cell DC/DC converter and the Variable DC approach in general is presented via different tests performed in the HIL test setup presented in Section IV. The system will be tested in the following conditions:

- Normal operation
- Sudden DC bus voltage transients (e.g., over- and undervoltage) in Freewheel mode
- Failures in the AC network, the propulsion system and the battery system.

A. Normal operation in Variable DC Approach

The power and voltage waveforms of the proposed system during normal operation are illustrated in Figure 6. The transition between the Variable DC approach modes is highlighted by vertical dashed black lines. At the start, the total load power, and consequently fuel cell power, is low, and thus the fuel cell voltage is above the DC bus voltage. Hence, the system operates in Buck mode. At 5s, the propulsion load is ramped up to 180 kW and the fuel cell power starts to increase. At 8s, the fuel cell voltage reaches the DC bus voltage, and the system enters the Freewheel mode where the fuel cell voltage equals the DC bus voltage. The fuel cell power keeps increasing towards total load power and at 14s, its voltage drops below the minimum DC bus voltage (i.e., 650V). Therefore, the system enters Boost mode, and the fuel

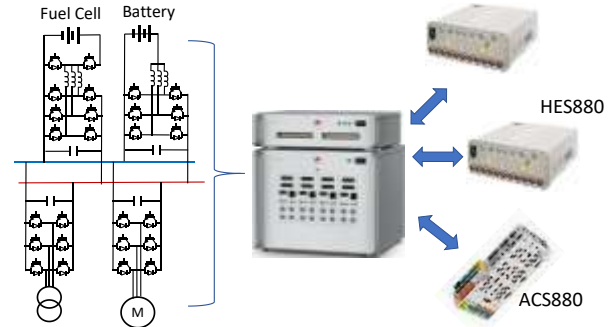

Fig. 5. A HIL test setup consisting of two FC units, a battery unit, a propulsion motor unit and an auxiliary load supply unit.

cell voltage is below the DC bus voltage. At 22s, the propulsion load is reduced to 90kW, and the system goes back to Freewheel mode. At 32s, the propulsion load is further reduced and at towards zero load, and the system ends up to Buck mode. The system is shown to perform smooth transitioning between the control modes and the power sources to properly satisfy the load demands of the propulsion and auxiliary loads. In the test, the auxiliary power was 15 kW over the complete time period.

B. Sudden DC bus voltage transient in Freewheel mode

In the Freewheel mode, the DC/DC converter switches are static, and the fuel cell current flows freely towards the DC bus and the fuel cell power is controlled by the battery DC/DC converter via control of the DC bus voltage. During this operation, power is ramped according to its allowed ramp rates, as was shown in Figure 6. However, the system may not always function properly, and the DC bus voltage may experience significant transients if a malfunction occurs. In such an event, the fuel cell DC/DC converter must be able to quickly limit the rate of change of fuel cell current to prevent

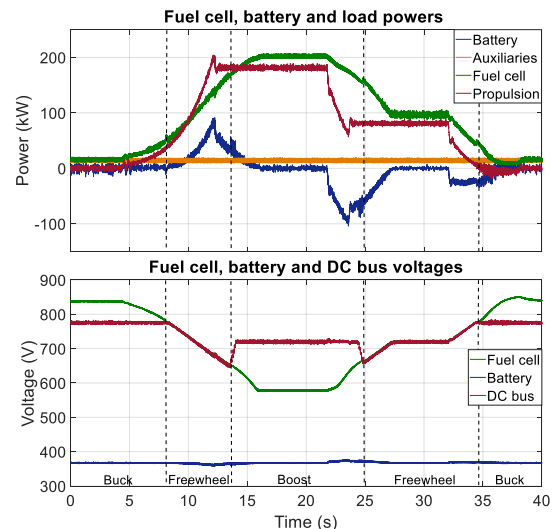

Fig. 6. Power and voltage waveforms of the proposed system during normal operation.

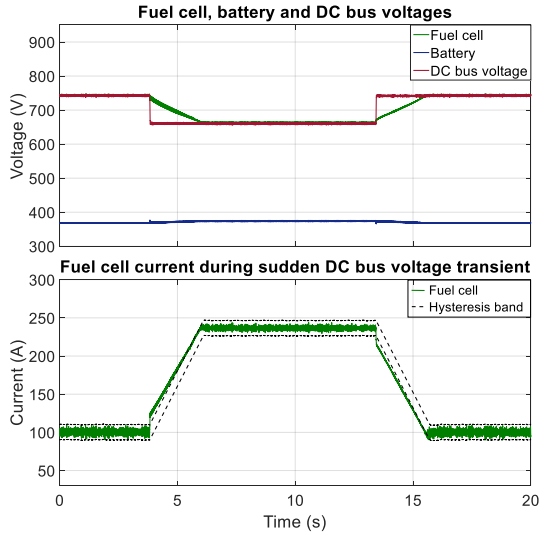

Fig. 7. Fuel cell current behavior in the Freewheel mode during a sudden DC bus voltage transient.

potential damage on the fuel cell stacks. Control of the fuel cell current rate of change was previously mentioned to be the role of the current ramp rate controller in the proposed control system described in Section III. The functionality of the proposed control system during a sudden DC bus voltage transient in Freewheel mode is illustrated in Figure 7. The rate limiters of the current ramp rate controller are set to 40 A/s. For illustrative purposes, at 3.5s, the battery DC/DC converter is commanded to suddenly reduce the DC bus voltage from 750V to 670V. The voltage drop leads to a sudden increase in fuel cell current, resulting in the current exceeding the hysteresis band of the current ramp rate controller. Therefore, the current ramp rate controller activates resulting in fuel cell current limitation, and thus for the system to temporarily exit Freewheel mode until the fuel cell voltage again reaches the DC bus voltage. At 13s, the DC bus voltage is increased back to 750V leading to rapid reduction in fuel cell current. This time, the fuel cell current undercuts the lower limit of the hysteresis band, and thus the current limitation activates.

C. Short-circuit fault in the AC network

In the AC network short-circuit test, a phase-to-phase short-circuit is created in the AC network. The system waveforms measured during the test are illustrated in Figure 8. At 0.17s, a short-circuit occurs between phases A and C. The top waveform in Figure 8 illustrates the current of the DC/AC converter for auxiliaries. The short-circuit is cleared within 100ms from its occurrence. The middle waveform of Figure 8 illustrates the system power during the fault, whereas the bottom waveforms illustrate the voltages. It can be noticed that the short-circuit event has only minor impact on the fuel cell power. Most of the impact is absorbed by the battery drive. The small power oscillations that can be noticed in the fuel cell power during the short-circuit event are due to oscillations in the DC bus voltage. The oscillation of the DC

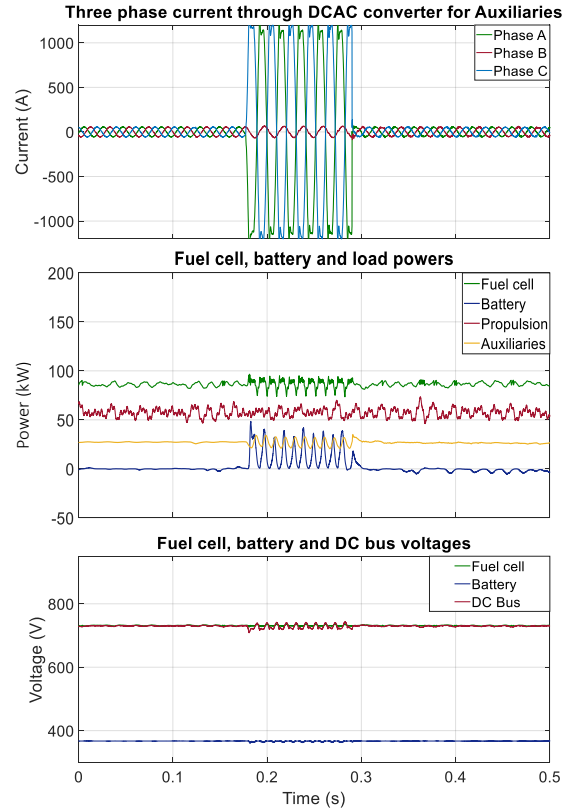

Fig. 8. System behavior during a phase-to-phase short circuit in the AC network. Short circuit occurs between phases A and C

bus voltage occurs because during the fault event, the battery DC/DC converter is not capable of maintaining a completely steady voltage during the short-circuit event. Nevertheless, such minor power oscillations for such a short time period are not considered problematic to the fuel cell power source. Similar load variation can be noticed in the auxiliary power which in this test being a constant power load tries to maintain constant power during the short-circuit event but is partially interrupted by the phase-to-phase short circuit.

D. Short-circuit fault in the motor power input terminals

Like in the AC network, failures may also occur in the propulsion motor drive. In this test, a phase-to-phase short-circuit is created in the input power terminals of the propulsion motor. The results of the test are illustrated in Figure 9. At 0.6s, a short-circuit occurs between motor phases A and C. The top waveform in Figure 9 illustrates the currents measured in the propulsion DC/AC converter. Upon noticing an overcurrent, the DC/AC converter trips and its output current is immediately cut, and thus causing a sudden load loss experienced by the rest of the system. In the second waveform of Figure 9, the motor power is seen to experience significant oscillation following the short circuit fault. That is because due to the short circuit, the motor torque oscillates significantly while the motor speed gradually drops to zero. However, this power oscillation does not transfer to the rest of

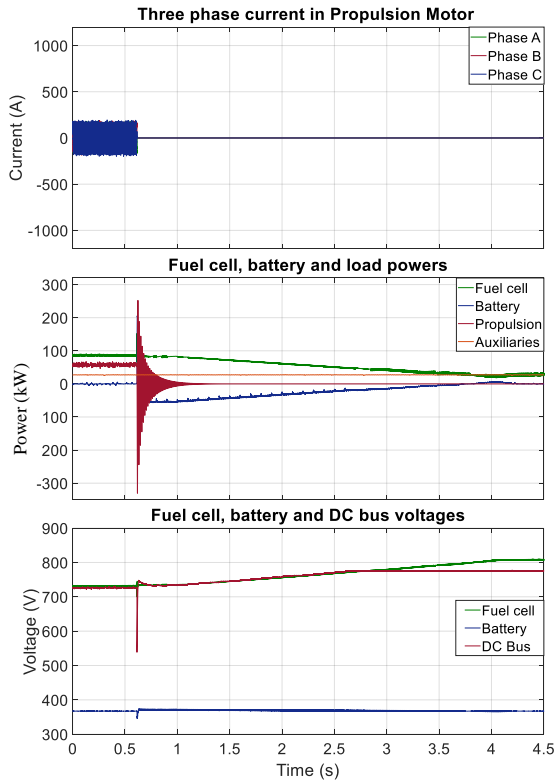

Fig. 9. System behavior during a phase-to-phase short circuit in the propulsion motor terminals.

the system due to the instant trip of the propulsion DC/AC converter. Nevertheless, between the occurrence of the short circuit and the trip of the DC/AC converter, a short power spike is caused by the fault, leading to a significant spike in the DC bus voltage. Like in Figure 7, the fuel cell ramp rate controller activates preventing rapid increase in fuel cell current. The fuel cell power is gradually reduced according to its ramp rates until it matches the total power demand.

E. Failure in the battery system

The Variable DC approach is highly dependent on the DC bus voltage control performed by the battery. However, like any component, the battery drive may also experience a malfunction which leads to sudden trip of a power source. A test where the system is operated during such an event is illustrated in Figure 10. At 0.5s, the battery DC/DC converter is tripped. At first, no noticeable impact is seen in power or voltage waveforms, which is naturally due to the battery power being zero prior to the battery drive trip. However, at 4s, the propulsion load is gradually reduced to zero. Since the fuel cell DC/DC converter is a current controlled device instead of a voltage controlled one, the power balance between the power sources and the loads is lost, and thus the DC bus voltage starts to increase. Due to increase in DC bus voltage and the system being in Freewheel mode, the fuel cell power decreases as well. Eventually, the rise in DC bus voltage activates the overvoltage controller of the fuel cell DC/DC

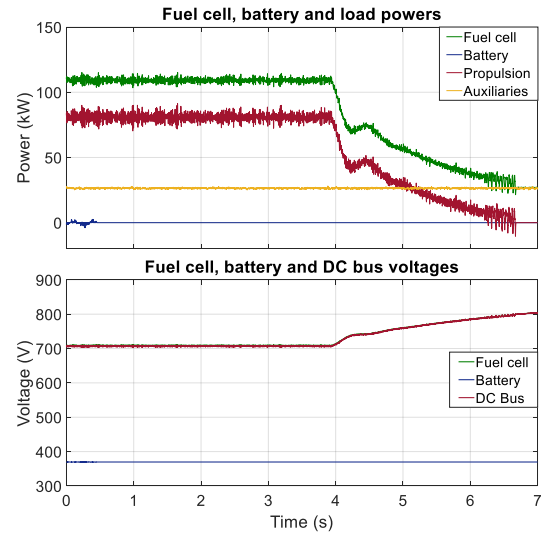

Fig. 10. System behavior following a failure in the battery system.

converter and limits the DC/DC converter voltage to 800V. This test illustrates that although the operation without the battery DC/DC converter is not a desired event, it does not lead into malfunction of the overall system. The fuel cell DC/DC converter will maintain the DC bus voltage within $[U_{dc_min}, U_{dc_max}]$ as long as i_{max_fc} is not exceeded. Nevertheless, in a practical application, it is recommended to always have redundancy in the battery drives to avoid operation without any battery power. Additionally, it should be noticed that in the test performed, the battery trip was caused while the battery was at zero load. Should the battery power be higher than the available power capacity in the fuel cell unit prior to a fault, the available fuel cell power might not be adequate to supply the total load would be needed from the power loads or else the whole system would be at risk of tripping on DC bus undervoltage.

F. DC bus overvoltage

The sixth test in this work was performed to evaluate the system behavior following a DC overvoltage event. In this test, the DC bus overvoltage level (i.e., U_{dc_max}) in the fuel cell DC/DC converter is set to 800V. The results of the test are shown in Figure 11. For illustrative purposes, the battery power is limited to a maximum 50kW. At 4.1s, the power of auxiliary load is reduced from 125 kW to 25 kW, and thus resulting in a rapid 100 kW reduction on load power. The battery drive reacts to the load change but is not able to fully absorb it due to limited power. The power mismatch between the power sources and the loads results into increased DC bus voltage. As the DC bus voltage approaches 800V, the overvoltage controller of the fuel cell DC/DC converter activates, resulting into a rapid decrease in fuel cell power to prevent the DC bus voltage from exceeding 800V. The DC bus voltage is maintained at 800V until the fuel cell power is gradually decreased to match the power demand of the loads. However, as can be observed, there is a period between 0.6s

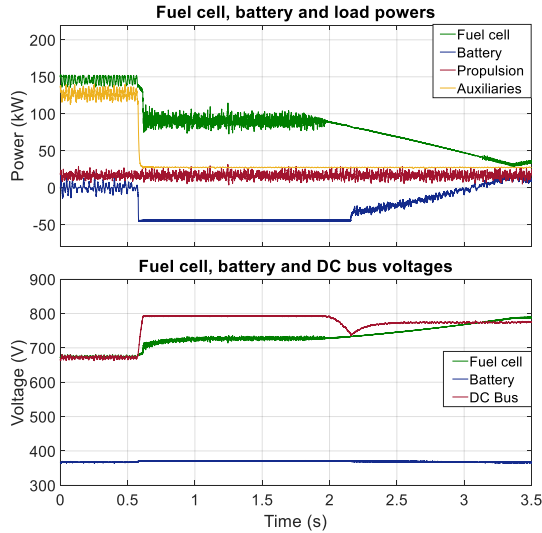

Fig. 11. System behavior during a DC bus overvoltage.

and 2s where the fuel cell power is locked to ~100kW instead of starting to immediately decrease towards the total load power (i.e., ~50kW). The cause for this is the current ramp rate controller of the fuel cell DC/DC converter. In this event, the overvoltage controller has overridden the current ramp rate controller in order to prevent the DC bus voltage from exceeding 800V. However, during the mentioned period, the fuel cell converter current is below the hysteresis band of the current ramp rate controller, and thus the current is prevented from further decreasing until the hysteresis band has decreased to a level where the fuel cell DC/DC converter current is again within the hysteresis band. That occurs at 2s where the fuel cell power continues its decrease.

G. DC bus undervoltage

The DC bus undervoltage test is performed similarly to the overvoltage test. The results are presented in Figure 12. At ~1.5s, the auxiliary load is rapidly increased from 25kW to 105kW, resulting in a rapid 80 kW increase in power demand. Again, the battery drive immediately reacts to the load change but is not able to fully absorb it due to its power being limited to 30 kW. Due to the power supply deficit, the DC bus voltage decreases and the fuel cell DC/DC converter undervoltage controller activates. The undervoltage controller increases the fuel cell power to i_{max_fc} . However, despite the increase in fuel cell power, total power supplied is still not enough to meet the total power demand, and thus the DC bus voltage continues its decrease. At ~1.9s, the undervoltage controller of the auxiliary DC/AC converter activates resulting in rapid decrease of auxiliary power, which in turn results in quick recovery of DC bus voltage. After recovery of DC bus voltage, auxiliary power supply resumes as well. During and following the event, the fuel cell power is gradually increased according to allowed power ramp rate until total power demand is met. ~At 3.2s, the system returns to Freewheel mode.

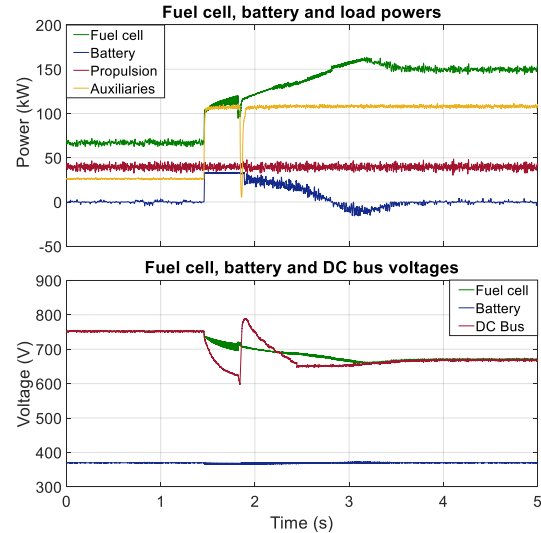

Fig. 12. System behavior during a DC bus undervoltage.

VI. CONCLUSIONS

Previously, the Variable DC approach concept was proposed for operation of hybrid fuel cell and battery powered marine vessels due to its improving impact on total powertrain losses. This paper has proposed a fuel cell DC/DC converter control system for the Variable DC approach concept. The functionality of the proposed control system was tested and verified under both normal operation conditions and various failure conditions using a HIL test setup with real converter controllers. The proposed controller was shown to perform well in the tested conditions.

The presented concept is currently being developed for future zero-emission marine vessels that are powered by fuel cells and batteries. For future research and further improvement, some parts of the Variable DC approach system could be further improved. For example, the system level tuning and control design could be improved to result in better transient stability in case of large overloads which result in significant DC bus undervoltage such as shown in Figure 12. Moreover, the proposed control system could be further improved to avoid the lock-up period which was discussed in Section V.F (time between 0.6s – 2s).

REFERENCES

- [1] A. Boglietti, P. Ferraris, M. Lazzari and F. Profumo, "Effects of different modulation index on the iron losses in soft magnetic materials supplied by PWM inverter," in *IEEE Transactions on Magnetics*, vol. 29, no. 6, pp. 3234-3236, Nov. 1993.
- [2] A. Krings, J. Soulard and O. Wallmark, "PWM Influence on the Iron Losses and Characteristics of a Slot-less Permanent Magnet Motor with SiFe and NiFe Stator Cores", *IEEE Transactions on Industry Applications*, Vol. 51, pp. 1475 – 1484, 2014.
- [3] C. Yu, J. Tamura and R. D. Lorenz, "Optimum DC Bus Voltage Analysis and Calculation Method for Inverters/Motors With Variable DC Bus Voltage," in *IEEE Transactions on Industry Applications*, vol. 49, no. 6, pp. 2619-2627, Nov.-Dec. 2013.

- [4] T. I. Bø, A. Swider and E. Pedersen, "Investigation of drivetrain losses of a DP vessel," *2017 IEEE Electric Ship Technologies Symposium (ESTS)*, Arlington, VA, 2017, pp. 508-513.
- [5] O. L. Osen, "Optimizing electric energy production on-board offshore vessels: Vessel power consumption profile and production strategies using genetic algorithms," *OCEANS*, Shanghai, 2016, pp. 1-10.
- [6] U. R. Prasanna, P. Xuwei, A. K. Rathore and K. Rajashekara, "Propulsion System Architecture and Power Conditioning Topologies for Fuel Cell Vehicles," *IEEE Transactions on Industry Applications*, vol. 51, no. 1, pp. 640-650, Jan.-Feb. 2015
- [7] K. K. Prabhakar, M. Ramesh, A. Dalal, C. U. Reddy, A. K. Singh and P. Kumar, "Efficiency investigation for electric vehicle powertrain with variable DC-link bus voltage," *42nd Annual Conference of the IEEE Industrial Electronics Society*, Florence, 2016, pp. 1796-1801.
- [8] S. Tenner, S. Gimther and W. Hofmann, "Loss minimization of electric drive systems using a DC/DC converter and an optimized battery voltage in automotive applications," *IEEE Vehicle Power and Propulsion Conference*, Chicago, IL, 2011, pp. 1-7.
- [9] T. Schoenen, M. S. Künter, M. D. Hennen and R. W. De Doncker, "Advantages of a variable DC-link voltage by using a DC-DC converter in hybrid-electric vehicles," *IEEE Vehicle Power and Propulsion Conference*, Lille, 2010, pp. 1-5.
- [10] J. Estima and A. Cardoso, "Efficiency Analysis of Drive Train Topologies Applied to Electric/Hybrid Vehicles," *IEEE Transactions on Vehicular Technology*, vol. 61, no. 3, pp. 1021-1031, March 2012.
- [11] A. Haxhiu, J. Kyyrä, R. Chan and S. Kanerva, "A variable DC approach to minimize drivetrain losses in fuel cell marine power systems," *IEEE Power and Energy Conference at Illinois (PECI)*, 2019, pp. 1-6.
- [12] A. Haxhiu, J. Kyyra, R. Chan, and S. Kanerva, "Improved variable dc approach to minimize drivetrain losses in fuel cell marine power systems," *IEEE Transactions on Industry Applications*, vol. 57, pp. 882–893, 2021.
- [13] A. Haxhiu, J. Kyyra, R. Chan, and S. Kanerva, "Modified variable dc approach applicable to fuel cells and dol batteries in shipboard power systems," *2020 9th International Conference on Renewable Energy Research and Application (ICRERA)*, 2020, pp. 158–163.
- [14] L. He, Z. Han, Y. Liu, Z. Niu and Z. Liu "Effects of Gas Starvation on Performance of a Single PEMFC", *IEEE Transportation Electrification Conference and Expo, Asia-Pacific*, 2017, pp. 1-5.
- [15] Typhoon HIL, "Typhoon HIL schematic library", 2021. [Online]. Available:<https://www.typhoon-hil.com/products/hil-software/schematic-editor>. [Accessed: 22- Aug- 2021]
- [16] ABB Oy, "HES880 Mobile Drive", 2021. [Online]. Available: <https://new.abb.com/drives/low-voltage-ac/industry-specific-drives/hes880>. [Accessed: 22- Aug- 2021]
- [17] ABB Oy, "ACS880-104 - inverter modules", 2021. [Online]. Available: <https://new.abb.com/drives/low-voltage-ac/industrial-drives/acs880-drive-modules/acs880-104>. [Accessed: 22- Aug- 2021]